

Clarke®

WOODWORKER



10" (255MM) SLIDING MITRE SAW CMS10S2B

PART NO: 6461515

OPERATION & MAINTENANCE INSTRUCTIONS

UK
CA

CE



ORIGINAL INSTRUCTIONS

DL0324 Rev 1

INTRODUCTION

Thank you for purchasing this CLARKE Mitre Saw.

Before attempting to use this product, please read this manual thoroughly and follow the instructions carefully. In doing so you will ensure the safety of yourself and that of others around you, and you can look forward to your purchase giving you long and satisfactory service.

Mitre saws are intended to cut wood or wood-like products, they cannot be used with abrasive cut-off wheels for cutting ferrous material such as bars, rods, studs, etc

IMPORTANT

Please pay particular attention to all sections of this user guide that display warning symbols and notices.



WARNING: THIS IS A WARNING SYMBOL. THIS SYMBOL IS USED THROUGHOUT THE USER GUIDE WHENEVER THERE IS A RISK OF PERSONAL INJURY. ENSURE THAT THESE WARNINGS ARE READ AND UNDERSTOOD AT ALL TIMES.

The work piece must have a minimum height of 3 mm and a minimum width of 10 mm. Make sure that the workpiece is always secured with the clamping device.

GUARANTEE

This product is guaranteed against faulty manufacture for a period of 12 months from the date of purchase. Please keep your receipt which will be required as proof of purchase.

This guarantee is invalid if the product is found to have been abused or tampered with in any way, or not used for the purpose for which it was intended.

Faulty goods should be returned to their place of purchase, no product can be returned to us without prior permission.

This guarantee does not effect your statutory rights.

SAFETY WARNINGS

WORK AREA

1. **Keep the work area clean and well lit.** Cluttered and dark areas invite accidents.
2. **DO NOT operate power tools in explosive atmospheres, such as in the presence of flammable liquids, gases or dust.** Power tools create sparks which may ignite the dust or fumes.
3. **Keep children and bystanders away while operating a power tool.** Distractions can cause you to lose control.

ELECTRICAL SAFETY

1. **Power tool plugs must match the outlet. Never modify the plug in any way. Do not use adapter plugs with earthed (grounded) power tools.** Unmodified plugs and matching outlets will reduce the risk of electric shock.
2. **DO NOT expose power tools to rain or wet conditions.** Water entering a power tool will increase the risk of electric shock.
3. **DO NOT abuse the power cable. Never use it for carrying, pulling or unplugging the power tool. Keep the power cable away from heat, oil, sharp edges or moving parts.** Damaged or entangled cables increase the risk of electric shock.
4. **When operating a power tool outdoors, use an extension cable suitable for outdoor use.** Use of a cable suitable for outdoor use reduces the risk of electric shock.
5. **If operating the power tool in a damp location is unavoidable, use a residual current device (RCD) protected supply.**

PERSONAL SAFETY

1. **Stay alert, watch what you are doing and use common sense when operating a power tool.** Do not use a power tool while you are tired or under the influence of drugs, alcohol or medication. A moment of inattention while operating power tools may result in personal injury.
2. **Use safety equipment. Always wear eye protection.** Safety equipment such as dust mask, non-skid safety shoes, hard hat, or hearing protection used for appropriate conditions will reduce personal injuries.
3. **Avoid accidental starting.** Ensure the switch is in the off position before plugging in. Carrying power tools with your finger on the switch or plugging in power tools that have the switch on invites accidents.
4. **Remove any wrench before turning the power tool on.** A wrench left attached to a rotating part may result in personal injury.

5. **Do not overreach.** Keep proper footing and balance at all times. This enables better control of the power tool in unexpected situations.
6. **Dress properly.** Do not wear loose clothing or jewellery. Keep your hair, clothing and gloves away from moving parts. Loose clothes, jewellery or long hair can be caught in moving parts.
7. A Laser beam can cause serious eye injury. Do not look into the laser outlet.

POWER TOOL USE AND CARE

1. **DO NOT force the power tool.** Use the correct accessories for your application. The correct power tool will do the job better and safer at the rate which it was designed.
2. **DO NOT use the power tool if the switch does not turn it on and off.** Any power tool that cannot be controlled with the switch is dangerous and must be repaired.
3. **Disconnect the plug from the power source before changing accessories, or storing power tools.** Such preventive safety measures reduce the risk of starting the power tool accidentally.
4. **Store idle tools out of the reach of children and do not allow persons unfamiliar with the power tool or these instructions to operate it.** Power tools are dangerous in the hands of untrained users.
5. **Maintain power tools.** Check for misalignment or binding of moving parts, breakage of parts and any other condition that may affect the power tool's operation. If damaged, have the power tool repaired before use. Many accidents are caused by poorly maintained power tools.
6. **Use the power tool and accessories in accordance with these instructions and in the manner intended, taking into account the working conditions and the work to be performed.** Use of the power tool for operations different from intended could result in a hazardous situation.

ADDITIONAL SAFETY RULES FOR MITRE SAWS

1. Use clamps to support the workpiece whenever possible. If supporting the workpiece by hand, you must always keep your hand at least 100 mm from either side of the saw blade. Do not use this saw to cut pieces that are too small to be securely clamped or held by hand. If your hand is placed too close to the saw blade, there is an increased risk of injury from blade contact.
2. The workpiece must be stationary and clamped or held against both the fence and the table.

3. **DO NOT** feed the workpiece into the blade or cut “freehand” in any way. Unrestrained or moving workpieces could be thrown at high speeds, causing injury.
4. Push the saw through the workpiece. Do not pull the saw through the workpiece. To make a cut, raise the saw head and pull it out over the workpiece without cutting, start the motor, press the saw head down and push the saw through the workpiece. Cutting on the pull stroke is likely to cause the saw blade to climb on top of the workpiece and violently throw the blade assembly towards the operator.
5. **NEVER** cross your hand over the intended line of cutting either in front or behind the saw blade. Supporting the workpiece “cross handed” i.e. holding the workpiece to the right of the saw blade with your left hand or vice versa is very dangerous.
6. **DO NOT** reach behind the fence with either hand closer than 100 mm from either side of the saw blade, to remove wood scraps, or for any other reason while the blade is spinning. The proximity of the spinning saw blade to your hand may not be obvious and you may be seriously injured.
7. Inspect your workpiece before cutting. If the workpiece is bowed or warped, clamp it with the outside bowed face toward the fence. Always make certain that there is no gap between the workpiece, fence and table along the line of the cut. Bent or warped workpieces can twist or shift and may cause binding on the spinning saw blade while cutting. There should be no nails or foreign objects in the workpiece.
8. **DO NOT** use the saw until the table is clear of all tools, wood scraps, etc., except for the workpiece. Small debris or loose pieces of wood or other objects that contact the revolving blade can be thrown with high speed.
9. Cut only one workpiece at a time. Stacked multiple workpieces cannot be adequately clamped or braced and may bind on the blade or shift during cutting.
10. Ensure the mitre saw is mounted or placed on a level, firm work surface before use. A level and firm work surface reduces the risk of the mitre saw becoming unstable.
11. Plan your work. Every time you change the bevel or mitre angle setting, make sure the adjustable fence is set correctly to support the workpiece and will not interfere with the blade or the guarding system. Without turning the tool “ON” and with no workpiece on the table, move the saw blade through a complete simulated cut to assure there will be no interference or danger of cutting the fence.
12. Provide adequate support such as table extensions, saw horses, etc. for a workpiece that is wider or longer than the table top. Workpieces longer or wider than the mitre saw table can tip if not securely supported. If the cut-

off piece or workpiece tips, it can lift the lower guard or be thrown by the spinning blade.

13. **DO NOT** use another person as a substitute for a table extension or as additional support. Unstable support for the workpiece can cause the blade to bind or the workpiece to shift during the cutting operation pulling you and the helper into the spinning blade.
14. The cut-off piece must not be jammed or pressed by any means against the spinning saw blade. If confined, i.e. using length stops, the cut-off piece could get wedged against the blade and thrown violently.
15. **ALWAYS** use a clamp or a fixture designed to properly support round material such as rods or tubing. Rods have a tendency to roll while being cut, causing the blade to “bite” and pull the work with your hand into the blade.
16. Let the blade reach full speed before contacting the workpiece. This will reduce the risk of the workpiece being thrown.
17. If the workpiece or blade becomes jammed, turn the mitre saw off. Wait for all moving parts to stop and disconnect the plug from the power source. Then work to free the jammed material.
18. After finishing the cut, release the switch, hold the saw head down and wait for the blade to stop before removing the cut-off piece. Reaching with your hand near the coasting blade is dangerous.
19. Hold the handle firmly when making an incomplete cut or when releasing the switch before the saw head is completely in the down position. The braking action of the saw may cause the saw head to be suddenly pulled downward.

SAFETY FOR THE HANDLING OF SAW BLADES

1. Check the condition of the blade before using the saw.
2. **DO NOT** use damaged or deformed saw blades.
3. **DO NOT** use saw blades made of high speed steel.
4. **ONLY** use saw blades recommended by the manufacturer.
5. Saw blades designed to cut wood and similar materials must comply with EN 847-1.
6. **DO NOT** use saw blades made of high-speed alloy steel (HSS steel). Only use replacement blades from your CLARKE dealer.
7. Observe the saw blade direction of rotation.
8. Clean any grease, oil and water off of the clamping surfaces.

9. ONLY use the saw blade supplied for cutting wood, never for the cutting of metals.
10. ONLY use saw blades with diameters in accordance with the markings on the saw.
11. Use additional workpiece supports, if required for workpiece stability.
12. Workpiece support extensions must always be secured and used during work.
13. Replace table inserts when worn
14. Avoid overheating of the saw teeth.
15. When sawing plastic, avoid melting of the plastic.
16. Use the appropriate saw blades for this purpose. Replace damaged or worn saw blades immediately.
17. When the saw blade overheats, stop the machine. Allow the saw blade to cool down before using the machine again.

LASER SAFETY



CAUTION: METHODS OTHER THAN THOSE SPECIFIED HERE CAN RESULT IN DANGEROUS RADIATION EXPOSURE.

1. DO NOT look directly into the laser beam with unprotected eyes.
2. NEVER look into the path of the beam.
3. NEVER point the laser beam towards reflecting surfaces and persons or animals. Even a laser beam with a low output can cause damage to the eyes.
4. NEVER open the laser module. Unexpected exposure to the beam can occur.
5. The laser may not be replaced with a different type of laser.
6. Repairs of the laser may only be carried out by the laser manufacturer or an authorised representative.







RESIDUAL RISKS

1. Despite all precautions having been met, some non-obvious residual risks may still remain.
2. Residual risks can be minimised if the “safety instructions” and the “Proper use” are observed along with the whole of the operating instructions.
3. DO NOT load the machine unnecessarily: excessive pressure when sawing will quickly damage the saw blade, which results in reduced output of the machine in the processing and in cut precision.
4. When cutting plastic material, please always use clamps: the parts being cut must always be fixed between the clamps.
5. Avoid accidental starting of the machine: the operating button may not be pressed when inserting the plug in an outlet.
6. Hands must never enter the cutting zone when the machine is in operation.



WARNING: THIS ELECTRIC TOOL GENERATES AN ELECTROMAGNETIC FIELD DURING USE. THIS FIELD CAN IMPAIR ACTIVE OR PASSIVE MEDICAL IMPLANTS UNDER CERTAIN CONDITIONS. IN ORDER TO PREVENT THE RISK OF SERIOUS OR DEADLY INJURIES, WE RECOMMEND THAT PERSONS WITH MEDICAL IMPLANTS CONSULT WITH THEIR PHYSICIAN AND THE MANUFACTURER OF THE MEDICAL IMPLANT PRIOR TO OPERATING THE SAW.

SAFETY SYMBOLS

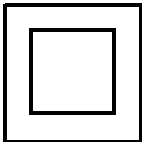
	<p>Read instruction manual and safety instructions</p>
	<p>Wear safety goggles!</p>
	<p>Wear ear defenders</p>
	<p>Wear a dust mask</p>
	<p>Important! Risk of injury. Never touch the moving saw blade!</p>
	<p>Laser Radiation, Class 2 Laser: Do not stare into the beam.</p>
	<p>Protection Class II (double shielded)</p>

ELECTRICAL CONNECTIONS



WARNING: READ THESE ELECTRICAL SAFETY INSTRUCTIONS THOROUGHLY BEFORE CONNECTING THE PRODUCT TO THE MAINS SUPPLY.

Before switching the product on, make sure that the voltage of your electricity supply is the same as that indicated on the rating plate. This product is designed to operate on 230VAC 50Hz. Connecting it to any other power source may cause damage.

This product may be fitted with a non-rewireable plug. If it is necessary to change the fuse in the plug, the fuse cover must be refitted. If the fuse cover becomes lost or damaged, the plug must not be used until a suitable replacement is obtained.

If the plug has to be changed because it is not suitable for your socket, or due to damage, it should be cut off and a replacement fitted, following the wiring instructions shown below. The old plug must be disposed of safely, as insertion into a mains socket could cause an electrical hazard.



**WARNING: THE WIRES IN THE POWER CABLE OF THIS PRODUCT ARE COLOURED IN ACCORDANCE WITH THE FOLLOWING CODE:
BLUE = NEUTRAL BROWN = LIVE**

If the colours of the wires in the power cable of this product do not correspond with the markings on the terminals of your plug, proceed as follows.

- The **Blue** wire must be connected to the terminal marked **N** or coloured **Black**.
- The **Brown** wire must be connected to the terminal marked **L** or coloured **Red**

Plug must be BS1363/A approved.

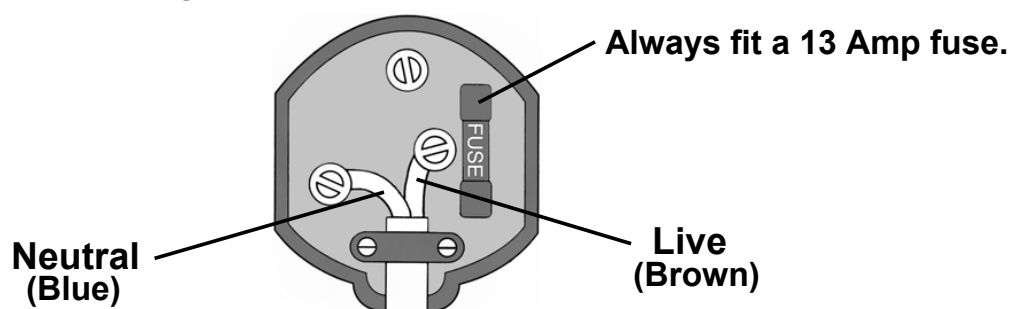

Ensure that the outer sheath of the cable is firmly held by the clamp

We strongly recommend that this machine is connected to the mains supply via a Residual Current Device (RCD)

If in any doubt, consult a qualified electrician. DO NOT attempt any repairs yourself.



This symbol indicates that this is a Class II product, and does not require an earth connection.

OVERVIEW

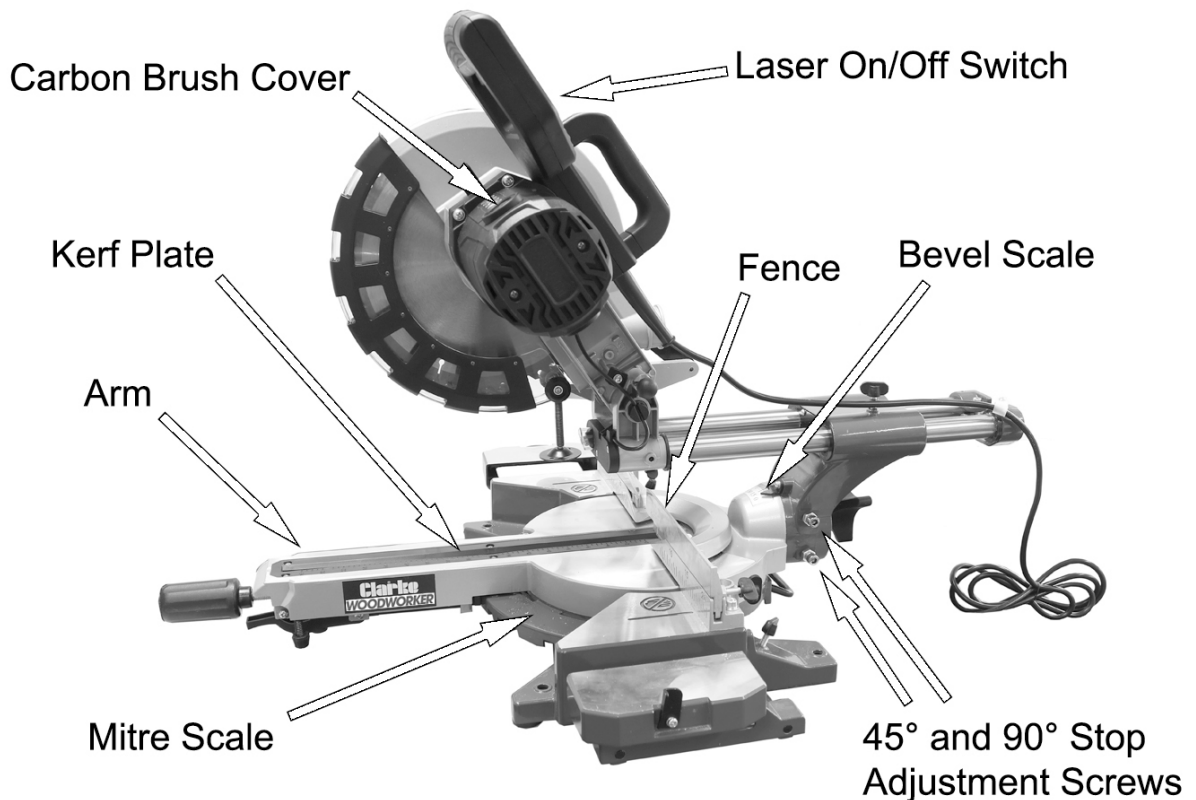
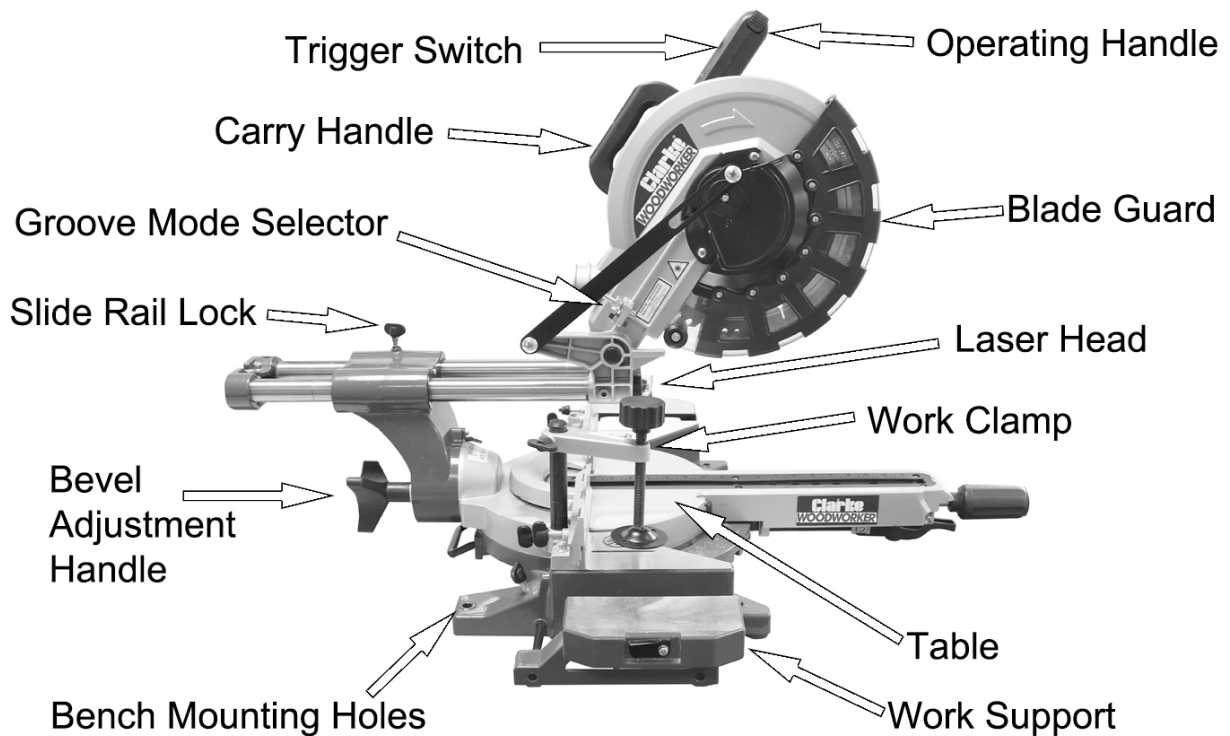

BEFORE USE

1. Remove the saw from the packing material carefully.
 - The following should be supplied. If anything is missing speak to your CLARKE dealer.

1 x Cross-Cut Mitre Saw with Laser Guide	1 x Blade - 255 mm x 30 mm x 2.8 mm x 48 TCT (in box).
1 x Clamping Device (fitted).	1 x 6 mm Hex Key
2 x Workpiece Supports (fitted).	1 x 3 mm Hex Key
1 x Blade - 255 mm x 30 mm x 2.8 mm x 48 TCT (fitted)	1 x Sawdust Bag

BENCH MOUNTING

Holes are provided in all four feet to facilitate bench mounting.

- Always mount your saw firmly on a level surface to prevent movement.

The saw can also be mounted to a piece of 12.5 mm or thicker plywood which can then be clamped to your work surface.

- When mounting your saw to a piece of plywood, make sure that the mounting screws do not protrude from the bottom of the wood.

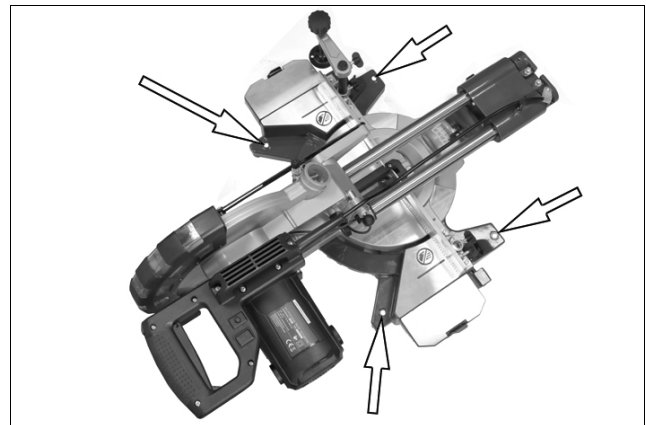

MITRE SAW STAND (NOT SUPPLIED)

You can also mount the machine to a mitre saw stand available from your local CLARKE dealer.

CUTS Mitre Saw Stand part No 6500944

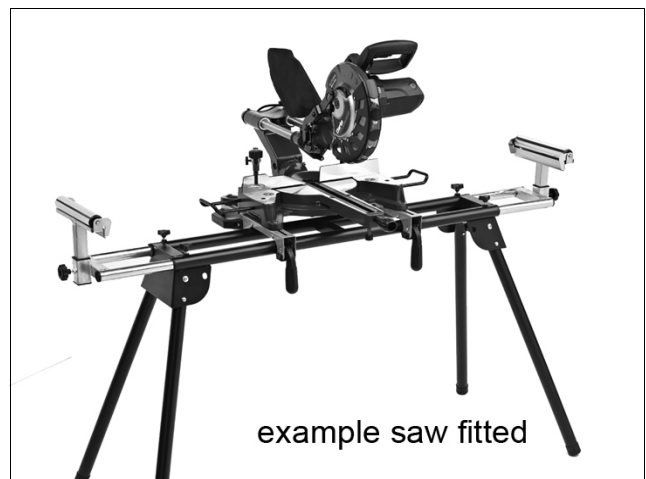

LOCKING / RELEASING THE SAW HEAD

1. Push down slightly on the operating handle and pull out the head locking pin and rotate it 90° degrees as shown so that the small pin rests on the grooves that hold the head locking pin in the unlocked position.

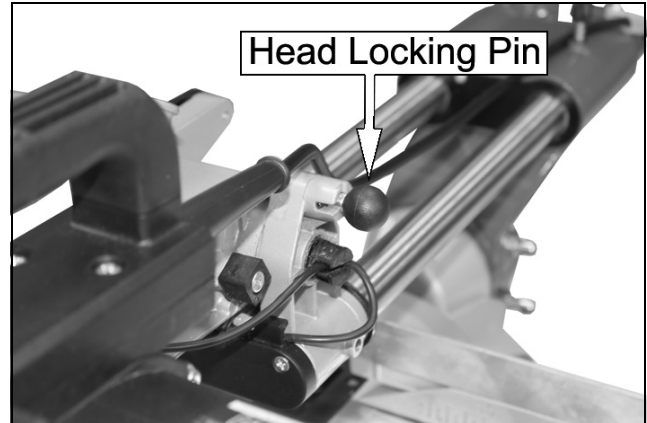

2. Carefully release the downward pressure on the operating handle and allow the head to rise to its full height.

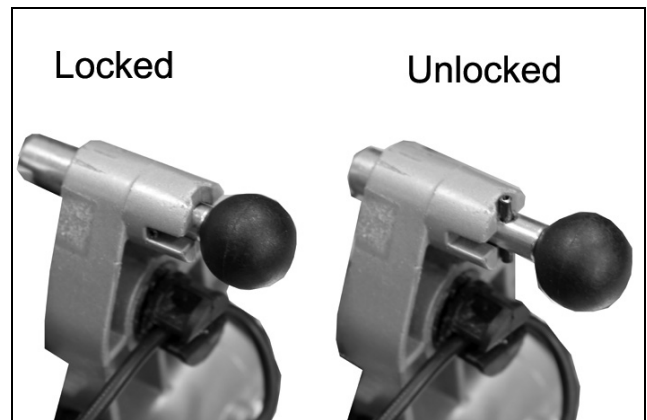

DUST EXTRACTION

This machine is provided with a dust extraction port for connection to a dust bag (supplied).

1. Squeeze together the metal ring on the dust bag and place it over the dust extraction port.
2. To empty the dust bag, use the zipper on the bottom of the dust bag.
3. The dust extraction port can also be connected to an extraction system using a suitable hose (not supplied)
 - The extraction system must be suitable for the material being worked.
 - Use appropriate filters when vacuuming dust as this is dangerous to your health or carcinogenic.

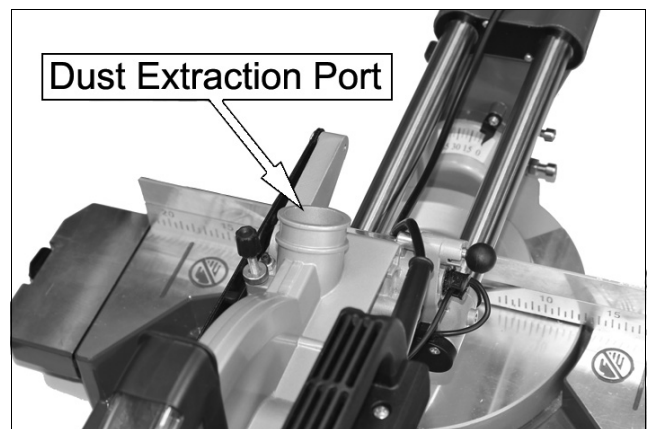

OPERATION

Always obey the safety instructions and applicable regulations.

BODY AND HAND POSITION

Correct positioning of your body and hands when you operate the mitre saw will make cutting easier and safer.

- Do not put your hands near the blade.
- Clamp the workpiece tightly to the table and the fence when making cuts.
- Release the trigger switch and keep your hands in position until the blade stops.
- Always make dry runs (without power) before cuts so that you can check the path of the blade.
- Do not cross your hands.

WORKPIECE SUPPORTS

To extend the supports.

1. Loosen the thumbscrew.
2. Pull out the support as far as necessary.
3. Tighten the thumbscrew again.

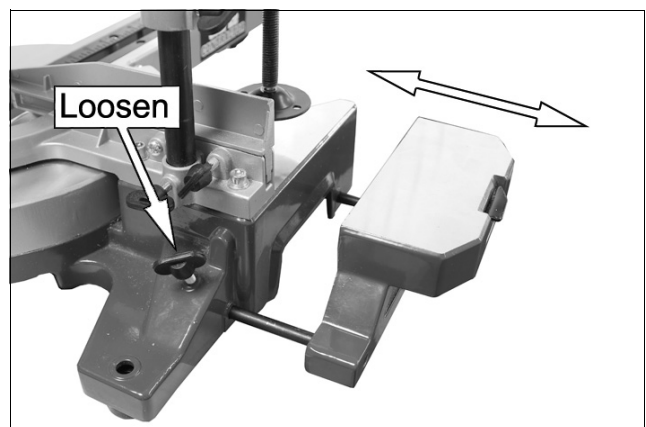

CLAMP POSITION

The clamp can be attached to either side of the saw table.

Insert the clamp in the holes behind the fence and secure it with the thumbscrew.

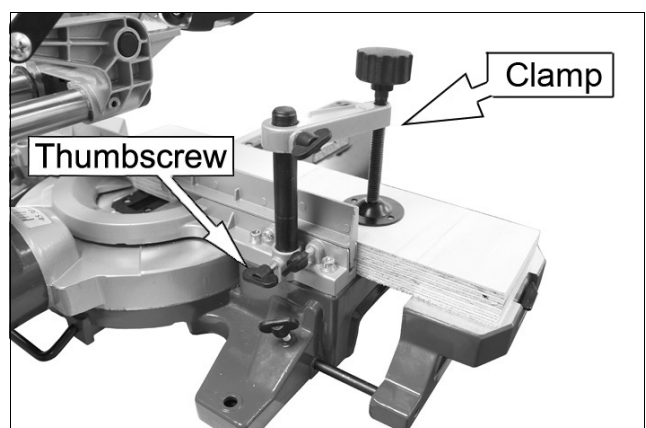

BASIC SAW CUTS

VERTICAL STRAIGHT CROSS CUT

1. Adjust the mitre table to 0° as shown on page 17.
2. Release the slide rail lock, and push the saw head back to the rear position.
3. Retighten the slide rail lock.
4. Put the wood to be cut against the fence and secure with the clamp.

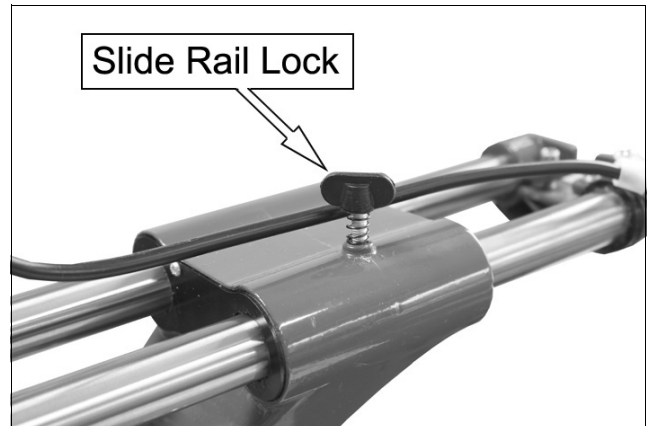

5. Push the trigger release (1) with your thumb and squeeze the trigger (2).
 - Let the motor reach full speed before cutting.

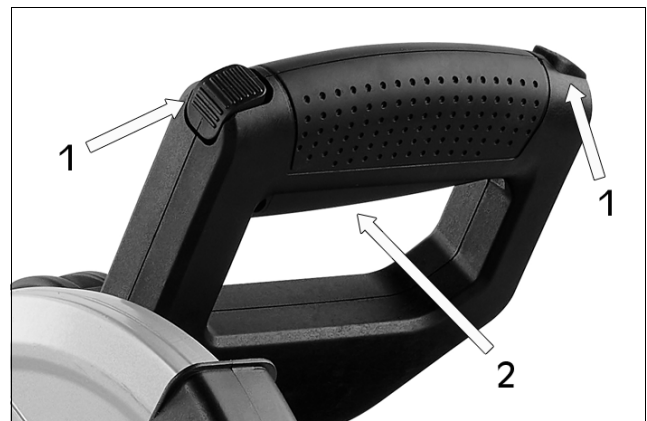

6. Lower the head slowly, allowing the blade to cut through the kerf plate.
 - **DO NOT** force the saw.
7. After the cut is complete, release the trigger and return the head to its upper rest position.

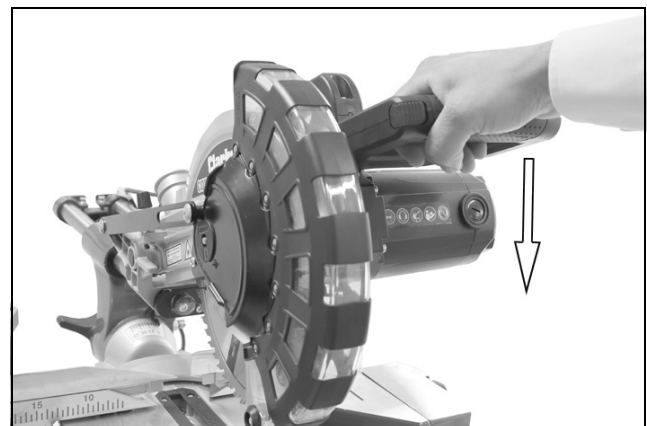

WARNING: THE BLADE WILL CONTINUE TO TURN FOR A SHORT WHILE AFTER YOU LET GO OF THE TRIGGER.

PERFORMING A SLIDING CUT

The slide rail lets you cut larger workpieces up to 340 mm x 90 mm using an out-down-back sliding motion.

1. Release the slide rail lock.

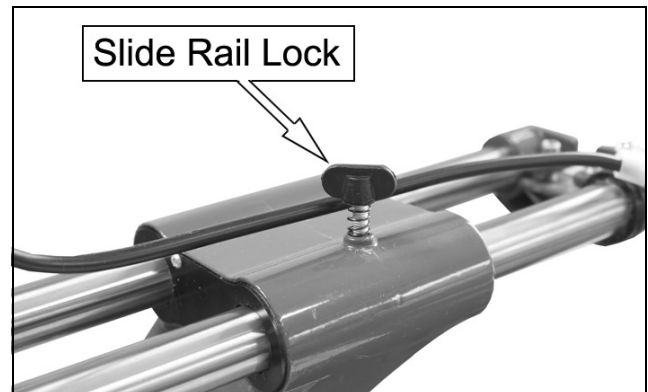

2. Push the trigger release (1) with your thumb and squeeze the trigger (2).

- Let the motor reach full speed.

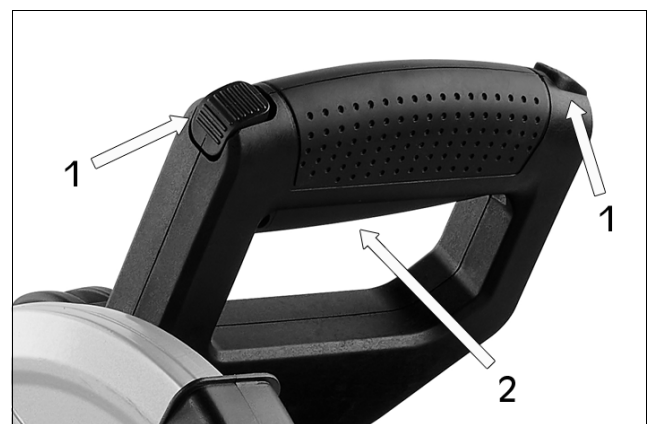

3. Pull the saw head towards you (1).

4. Lower the saw blade (2) into the workpiece.

5. Push the saw head back (3) to complete the cut.

- Do not perform sliding cuts on workpieces smaller than 50 x 100 mm.
- Lock the saw head in the rear position when the sliding cuts are complete.

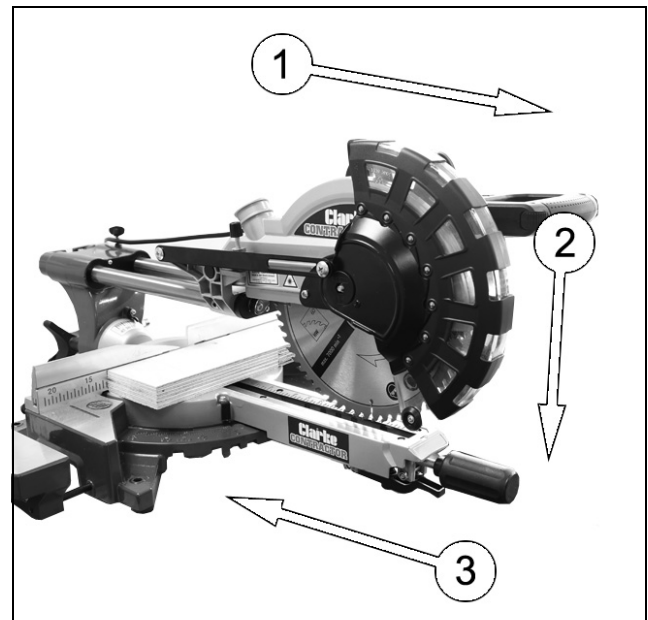

PERFORMING A MITRE CUT

1. To adjust the mitre saw table, loosen the handle approximately 2 turns counter clockwise.

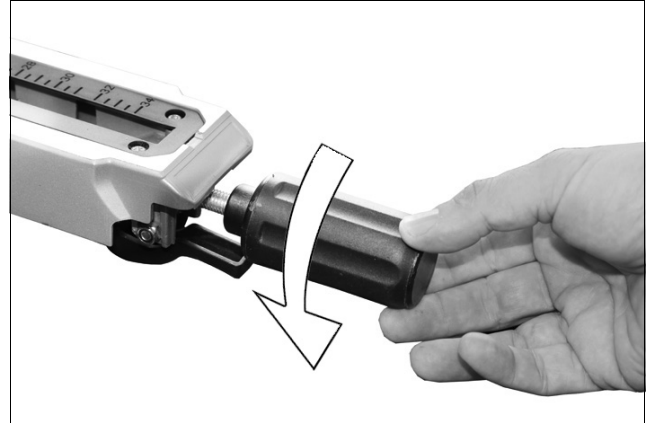

2. Pull up the locking lever.



3. Turn the table and pointer to the necessary angle (0° to 45° left or right).

- The angle is shown on the scale.

4. Release the locking lever and tighten the handle clockwise to secure it.

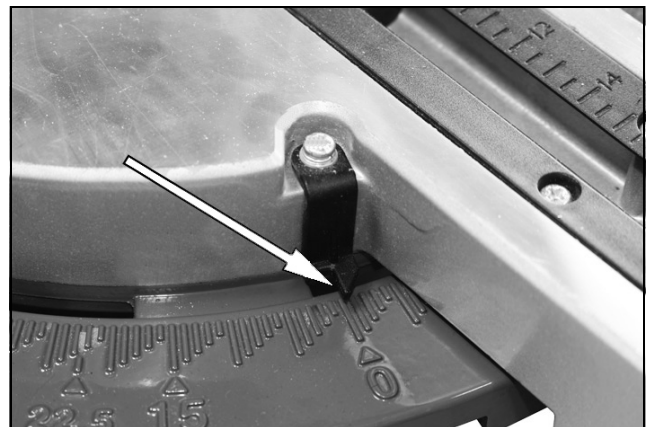

5. Every time you change the mitre angle, make sure the adjustable fences are set correctly to support the workpiece and will not interfere with the blade or the guarding system.

- The gap between the fence and the blade should be a maximum of 8mm.

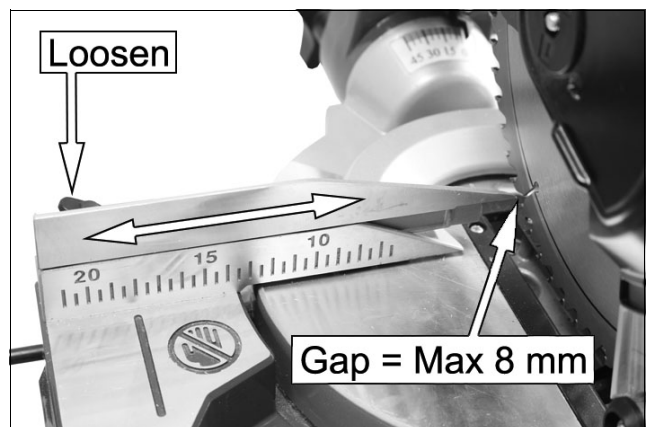

BEVEL CUTS

Bevel angles can be set from 45° left to vertical.

1. Loosen the bevel adjustment handle.
2. Set the bevel to the correct angle as shown on the scale.
3. Tighten the bevel adjustment handle.
4. Continue as for a vertical straight cross-cut.
 - For bevel cuts, the clamp must only be attached to the right side of the table.
5. Every time you change the bevel angle, make sure the adjustable fences are set correctly to support the workpiece and will not interfere with the blade or the guarding system.
 - The gap between the fence and the blade should be a maximum of 8mm.

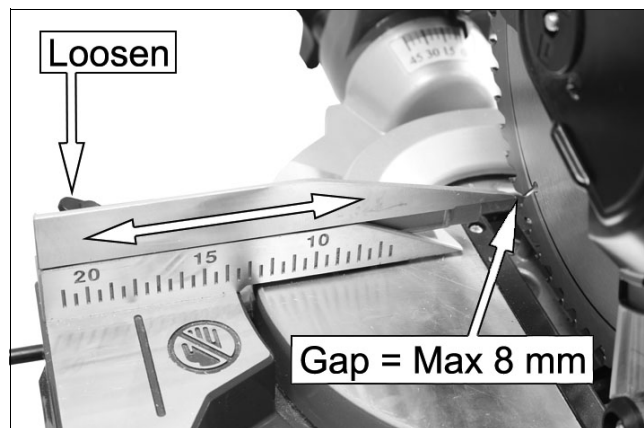
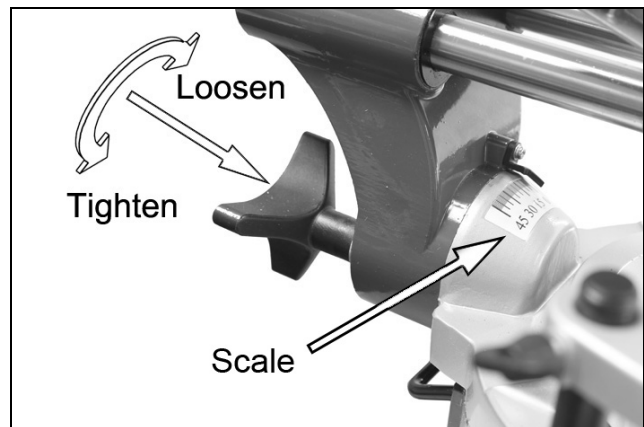

COMPOUND MITRE CUTS

A compound mitre is a cut made using a mitre angle and a bevel angle at the same time. This is the type of cut used to make frames or boxes with slanting sides.

1. Set your saw to the necessary angles.
 - Always try cuts on scrap pieces of wood to verify the settings on the saw.
2. Practice fitting the cut pieces together.



LIMITING THE DEPTH OF CUT (GROOVE CUTTING)

1. Subtract the depth of your groove from the thickness of your workpiece.

- This will give you the height above the table surface at which the saw blade must be set.

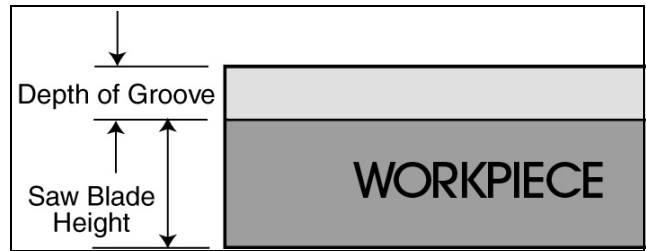

- For example if you want a 6 mm deep groove in a 18 mm thick piece of wood, you need a saw blade height of 12 mm (18 mm - 6 mm).

2. Put a template or a piece of wood, the same thickness as the saw blade height setting, on the table, below the saw blade.

- As an example a piece of wood 12 mm thick.

3. Lower the head until it lightly touches the template.

4. Loosen the locking ring (2) if required, screw down the adjuster (1) until it touches the ledge, then finally tighten the locking ring (2).

- The saw blade is now set to cut your groove, using the sliding feature.

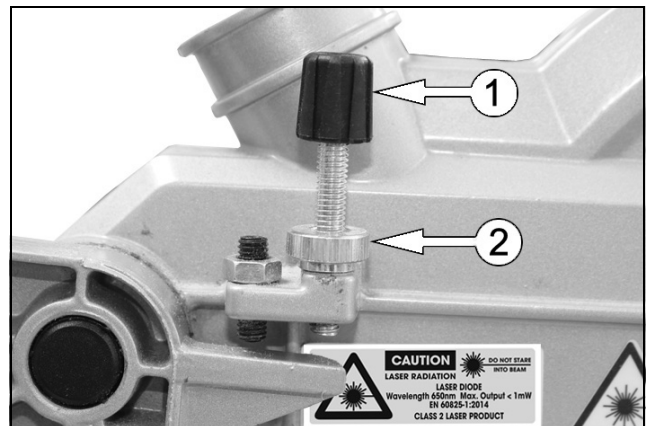

- The width of the groove will, of course, be the width of the saw blade. However, if you move the workpiece along the table in small increments, it is possible to cut grooves to any width.

5. Before reverting to normal cutting, remember to reset the position of the adjuster to its normal position.

THE LASER GUIDE



Laser Radiation, Class 2 Laser: Do not stare into the beam.

TO SWITCH ON:

1. Push the laser ON/OFF switch once.
 - A laser line is projected onto the material, providing an accurate guide for the cut.



TO SWITCH OFF:

1. Push the laser ON/OFF switch again.

ADJUST THE LASER

If the laser does not show the correct cut line, you can use the following procedure to adjust the laser.

1. Turn the laser on.
2. Remove the screws shown.
3. Remove the front cover.
4. Loosen the cross head screws and adjust the laser by moving sideways until the laser beam hits the teeth of the saw blade.
5. Retighten the cross head screws.
6. Replace the front cover and tighten the two screws.

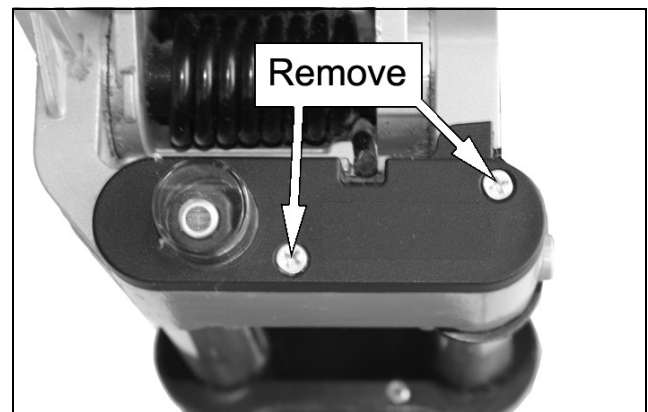

ADJUSTMENTS



WARNING: MAKE SURE THAT THE SAW IS SWITCHED OFF AND DISCONNECTED FROM THE MAINS SUPPLY BEFORE MAKING ANY ADJUSTMENTS.

CHECK AND ADJUST THE MITRE ANGLE

1. Lock the saw head in the down position see page 13.
2. Put a set square up against the left side of the fence and blade.
3. Adjust the mitre arm if necessary until the blade is perfectly square to the fence.

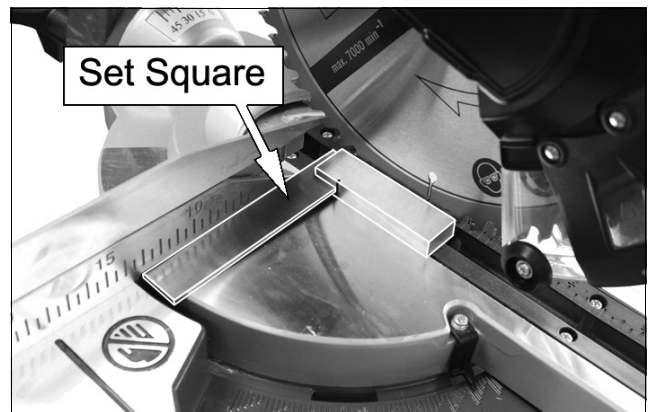

4. If pointer does not point to zero on the mitre scale, loosen the screw that attaches the pointer and move the pointer as necessary.

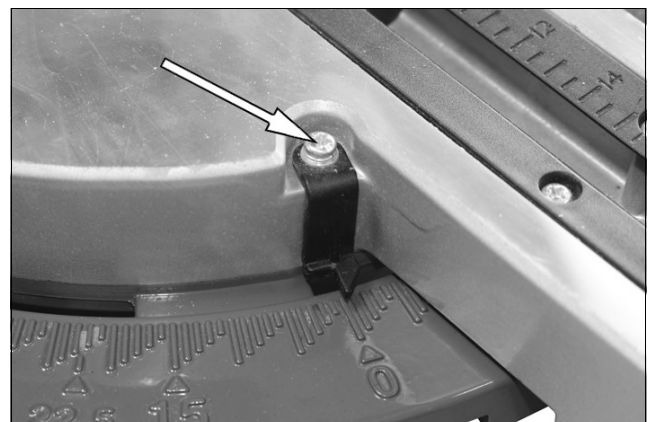

CHECK AND ADJUST THE BEVEL ANGLE

1. Loosen the bevel adjustment handle.
2. Push the saw head to the right to vertical and tighten the bevel clamp handle.
3. Lock the saw head in the down position see page 13.

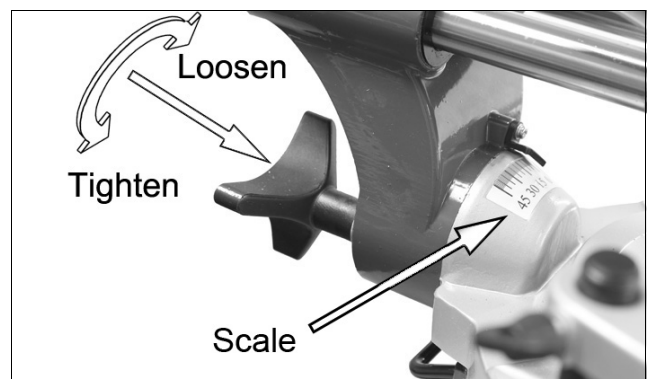

90 DEGREE STOP ADJUSTMENT

- Put a set square on the table and up against the blade.

NOTE: Do not touch the tips of the blade teeth with the square.

If adjustment is necessary, continue as follows:

- Loosen the lock nut and turn the 90° adjustment stop screw in or out until the blade is at 90° to the table as shown by the set square.
- If the bevel pointer does not point to zero on the bevel scale, loosen the screw that secures the bevel pointer and move the pointer as necessary.

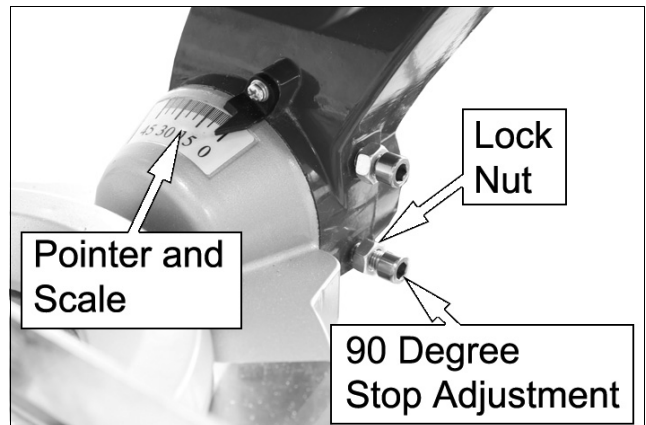
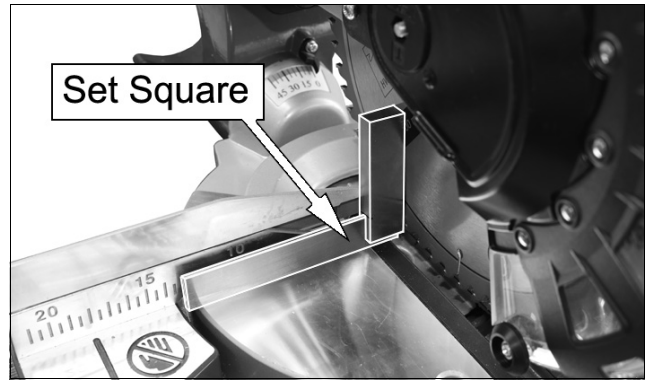

45 DEGREE STOP ADJUSTMENT

- Loosen the bevel adjustment handle and set the saw head as far to the left as possible (this should be the 45° angle)
- Put a 45° set square on the table and up against the blade.

NOTE: Do not touch the tips of the blade teeth with the square.

- Loosen the lock nut and turn the 45° adjustment stop screw in or out until the blade is at 45° to the table as measured with the square.
- Adjust the bevel pointer if necessary as shown in point 6 above.

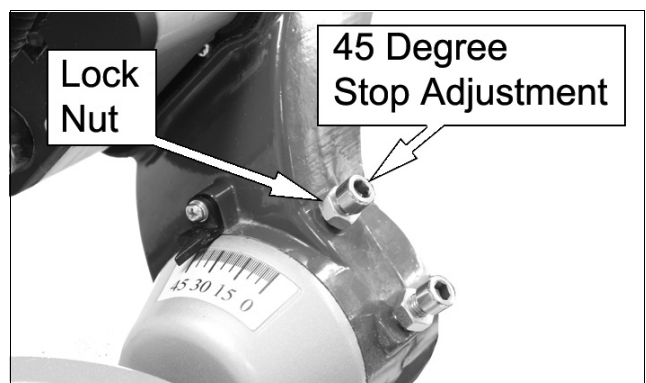

TRANSPORTING

- Lower the head and lock it down using the head lock pin.
- Slide the head towards you and secure in position using the slide rail lock.
- Lock the mitre arm with the table mitre lock.
- Lock the bevel adjustment handle with the saw head in the vertical position to make the tool as compact as possible.
- Always lift the saw using the table.

MAINTENANCE



WARNING: MAKE SURE THAT THE SAW IS SWITCHED OFF AND UNPLUGGED FROM THE MAINS SUPPLY BEFORE FITTING OR REMOVING THE BLADE.

WARNING: WEAR SAFETY GLOVES WHEN CHANGING THE SAW BLADE.

WARNING: THE REPLACEMENT BLADE MUST BE RATED TO AT LEAST 4500 RPM.

CHANGING THE SAW BLADE

1. Loosen the retaining screw of the cover using a Phillips screwdriver.

NOTE: Do not fully remove this screw.

2. Fold the saw blade guard upwards until the saw blade guard is above the flange screw.

3. Insert the hex key supplied in the flange screw.

4. Push the saw shaft lock and slowly rotate the flange screw using the hex key in clockwise direction.

- The saw shaft lock engages after no more than one rotation.

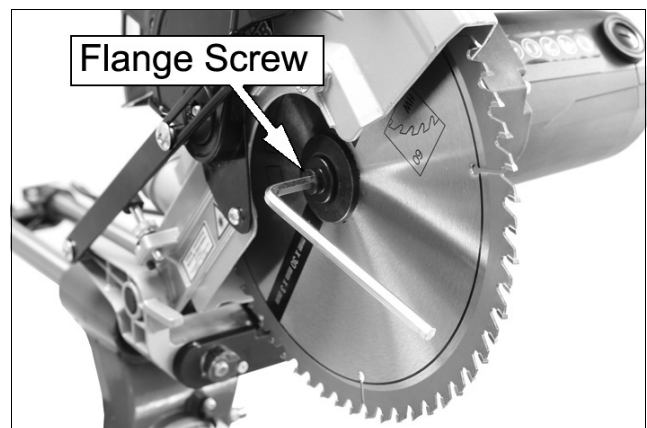
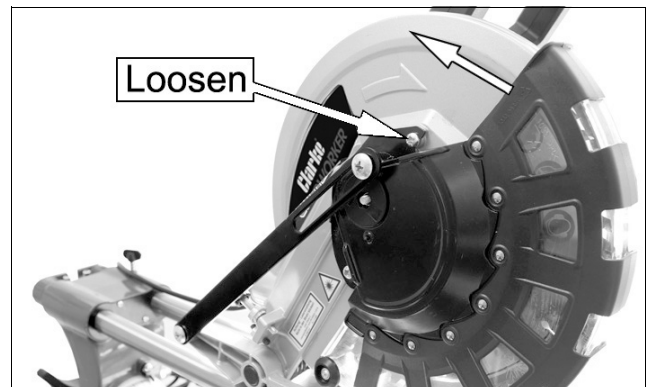

WARNING: NEVER PUSH THE BLADE LOCK IN WHEN THE MOTOR IS RUNNING.

5. Remove the flange screw and outer flange.
6. Remove the blade from the inner flange.
7. Carefully clean the flange screw, outer flange and inner flange.
8. Fit a new saw blade in reverse order.
 - Please note that spare blades are available from your CLARKE dealer.
 - Make sure that all parts are perfectly clean and the blade teeth point down at the front.
 - Every time that you change the saw blade, check to see that it spins freely in the table insert in both perpendicular and 45° angle settings.
9. Before continuing your work make sure that all safety devices are in good working condition.

REPLACING THE TABLE INSERT



WARNING: IF THE TABLE INSERT IS DAMAGED THERE IS A RISK OF SMALL PARTS GETTING STUCK BETWEEN TABLE INSERT AND SAW BLADE, BLOCKING THE SAW BLADE. REPLACE DAMAGED TABLE INSERTS IMMEDIATELY!

1. Remove screws at table insert. If required, turn rotary table and incline saw head to be able to reach the screws.
2. Remove table insert.
3. Install new table insert.
4. Tighten the screws at table insert.

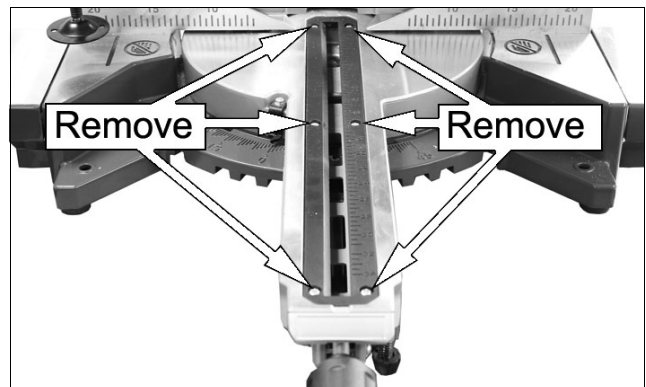

CHANGING THE CARBON BRUSHES



WARNING: MAKE SURE THAT THE SAW IS SWITCHED OFF AND UNPLUGGED FROM THE MAINS SUPPLY BEFORE INSPECTING OR CHANGING THE CARBON BRUSHES.

Check the carbon brushes after the first 50 operating hours with a new machine, or when new brushes have been fitted. Then every 10 operating hours.

1. Unscrew the carbon brush cover.

2. Pull out the carbon brushes.
 - If the carbon is worn to a length of 6 mm or less, or if the spring or contact wire is burned or damaged, replace both brushes.
3. Replace the carbon brush cover, taking care not to cross thread it.

CLEANING

Your saw has been designed to operate over a long period of time with a minimum of maintenance. Continuous satisfactory operation depends upon proper tool care and regular cleaning.

- Keep the ventilation slots clear and regularly clean the motor housing with a soft cloth.
- Regularly clean the table top.
- Regularly clean the dust collection bag.
- Avoid the use of cleaners or lubricants to maintain the tool. In particular spray and aerosol cleaners may chemically attack the plastic lower guard.

ENVIRONMENTAL PROTECTION



Recycle unwanted materials instead of disposing of them as waste. All tools, accessories and packaging should be sorted, taken to a recycling centre and disposed of in a manner which is compatible with the environment.

By purchasing this product, the customer is taking on the obligation to deal with its safe disposal in accordance with the Waste Electrical and Electronic Equipment (WEEE).

In effect, this means that this product must not be disposed of with general household waste. It must be disposed of according to the laws governing Waste Electrical and Electronic Equipment (WEEE) at a recognised disposal facility. If disposing of this product or any damaged components, do not dispose of with general waste. This product contains valuable raw materials. Metal products should be taken to your local civic amenity site for recycling of metal products.

SPECIFICATIONS

Model Number	CMS10S2B
Part Number	6461515
Rated Voltage	230 V AC @ 50Hz
Input Wattage	2000 W
Blade Diameter	255 mm
Blade bore	30 mm
Max. blade thickness	2.8 mm
Max. blade speed	7000 rpm
Max. crosscut capacity at 90°	340 mm x 90 mm
Max. bevel cross-cut 45°	240 mm x 90 mm
Max Bevel cut @ 45°	340 mm x 45 mm
Compound mitre cut	240 mm x 45 mm
Max Bevel Angle	0-45° to the left
Sound pressure (L_{pA})	101.6 dB (A)
Sound power (L_{WA})	114.6 dB (A)
Uncertainty Factor (K)	3
Dimensions (Length x Width x Height)	770 x 595 x 580 mm
Weight	14.3 kg



WARNING: THE NOISE EMISSIONS DURING THE ACTUAL USE OF THE POWER TOOL MAY DIFFER FROM THE ABOVE-MENTIONED VALUES DEPENDING ON THE TYPE OF WORKPIECE BEING PROCESSED.

EXPLODED DIAGRAM

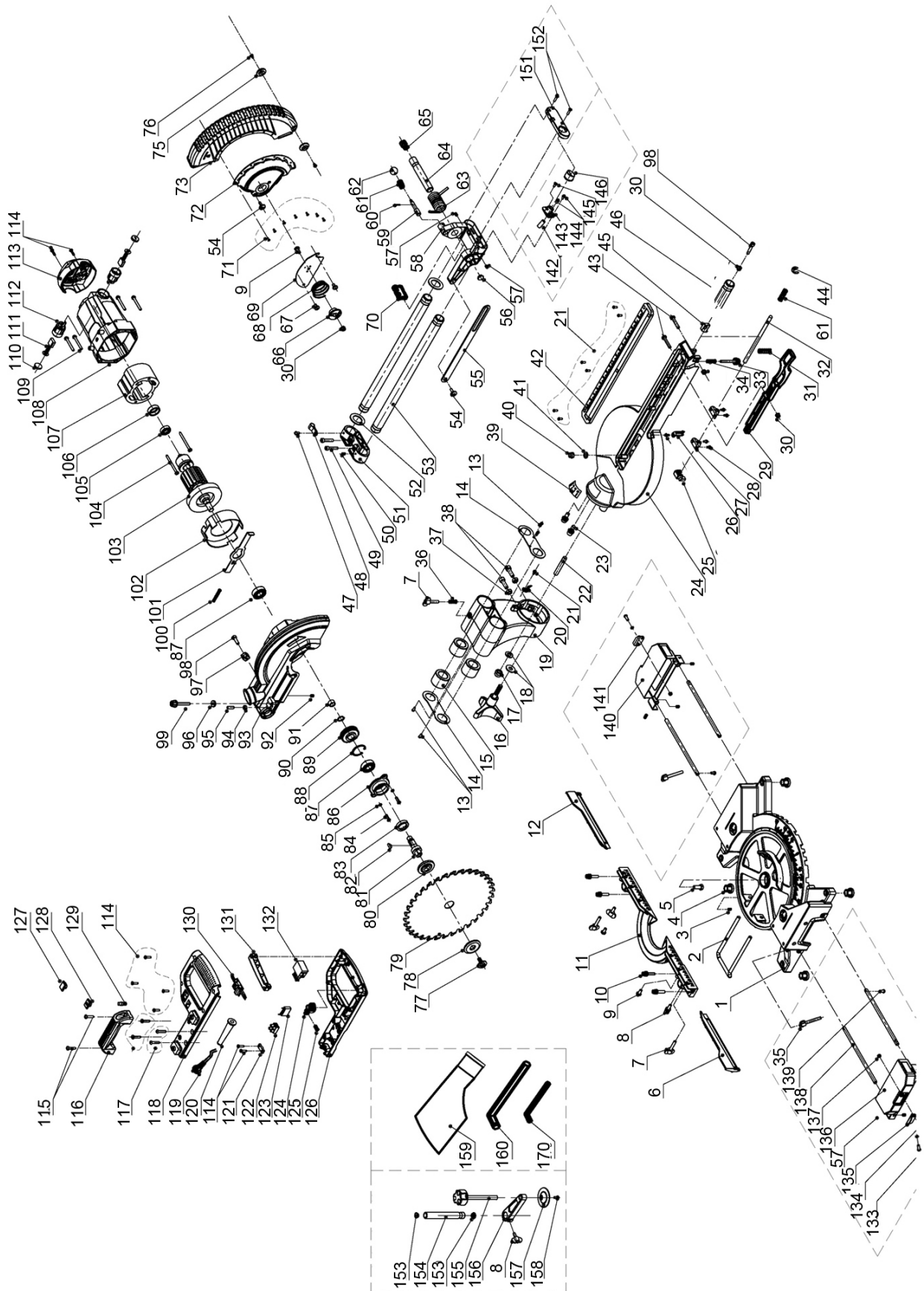

PARTS LIST

No	Description
1	Base
2	Rear support bar
3	Socket set screw
4	Rubber foot
5	Hexagon bolt
6	Left fence
7	Butterfly screw
8	Butterfly screw
9	Cross recessed pan head screws
10	Hexagon socket screws
11	Fence support
12	Right fence
13	Cross recessed pan head screw
14	Linear bearing end cover
15	Linear bearing
16	Angle lock knob
17	Type 2 non-metallic lock nut
18	Washer
19	Connecting body
20	Mitre angle pointer
21	Cross recessed pan head screw
22	Hexagon socket set screw
23	Socket head cap screw
24	Swivel base
25	Friction block
26	Angle pointer
27	Disc locking bar support
28	Cross recessed pan head screw
29	Locking arm
30	Type 2 non-metallic hex lock nut
31	Fixed bar spring

No	Description
32	Swivel base locking rod
33	Lock knob
34	Switch trigger spring
35	Wing screw
36	Bar lock spring
37	Nut
38	Socket head cap screw
39	Angle label
40	Type 2 non-metallic hex locknut
41	Flat pad
42	Kerf plate
43	Cross pan head screws
44	Locking top block
45	Side handle support block
46	Side handle
47	Cross recessed pan head screw
48	Wire guide
49	Socket head cap screw
50	Socket flat end set screw
51	Rod end brace
52	Guide rod end buffer
53	Guide rod
54	Cross recessed pan head screw
55	Moving guard tie bar
56	Shaft end cap
57	Grub screw
58	Pivot bracket
59	Self-locking pin
60	Roll pin
61	Self-locking pin spring
62	Ball nut

No	Description
63	Large torsion spring
64	Pivot shaft
65	End plug
66	Cover plate
67	Cross recessed pan head screw
68	Spring
69	Plate cover
70	Dust cover
71	Rivet
72	Guard hinge plate
73	Moving guard
74	n/a
75	n/a
76	Cross pan head self-tap screw
77	Blade retaining screw
78	Blade retaining disc
79	Saw blade
80	Inner retaining disc
81	Driveshaft
82	Woodruffe key
83	Oil seal
84	Cross head countersunk screw
85	Bowl-shaped washer
86	Front bearing cover
87	Bearing
88	Circlip
89	Drive gear
90	Circlip
91	Needle bearing
92	Set screw
93	Head shell
94	Nut
95	Setscrew
96	Knurled thin nut

No	Description
97	Anti-collision block
98	Socket head cap screw
99	Lock knob
100	Self-locking spring
101	Shaft locking tab
102	Air shield
103	Rotor
104	Cross head pan head s/t screw
105	Bearing
106	Bearing sleeve
107	Stator
108	Motor case
109	Cross recessed pan head screw
110	Brush cover
111	Brush
112	Brush holder
113	Back cover
114	Cross pan head s/t screw
115	Cross pan head s/t screw
116	Handle
117	Cross pan head screws
118	Upper control handle
119	Power cable
120	Cable gland
121	Cable clamp
122	Terminal
123	Capacitor
124	Switch self-locking button
125	Button spring
126	Lower handle
127	Plastic cover
128	Ejector base
129	Ejector
130	Circuit board

No	Description
130	Circuit board
131	Switch trigger
132	Switch
133	Cross recessed panhead screw
134	Spring washer
135	Left wing tab
136	Left wing
137	Type 2 hexagon lock nut
138	Rod extension
139	Cross recessed pan head screws
140	Right wing
141	Right wing tab
142	Laser
143	Laser base
144	Cross recessed pan head screws
145	Countersunk s/t screw

No	Description
146	Laser transparent cover
147	n/a
148	n/a
149	n/a
150	n/a
151	Laser light holder
152	Cross countersunk head screw
153	Fixed rod end cap
154	Fixed rod
155	Hand knob/threaded rod
156	Arm
157	Disc
158	Grub screw
159	Dust bag
160	Hexagonal (allen) key 6mm
170	Hexagonal (allen) key 3mm

DECLARATION OF CONFORMITY



Fitzwilliam Hall, Fitzwilliam Place, Dublin 2

DECLARATION OF CONFORMITY

This is an important document and should be retained.

We hereby declare that this product(s) complies with the following directive(s):

- 2014/30/EU Electromagnetic Compatibility Directive.
- 2006/42/EC Machinery Directive.
- 2011/65/EU Restriction of Hazardous Substances, (amended by 2015/863).

The following standards have been applied to the product(s):

- EN 55014-1:2017, EN 55014-2:2015, EN 61000-3-2:2014, EN 61000-3-11:2000, EN 62841-1:2015, EN 62841-3-9:2015+A11:2017.

The technical documentation required to demonstrate that the product(s) meet(s) the requirement(s) of the aforementioned directive(s) has been compiled and is available for inspection by the relevant enforcement authorities.

The CE mark was first applied in: 2020

Product Description: 255mm Sliding Mitre Saw
Model number(s): CMS10S2B
Serial / batch Number: N/A
Date of issue: 04/03/2021

Signed:

J.A. Clarke
Director



Hemnal Street, Epping, Essex, CM16 4LG

DECLARATION OF CONFORMITY

This is an important document and should be retained.

We hereby declare that this product(s) complies with the following UK legislation:

- Electromagnetic Compatibility Regulations 2016.
- Supply of Machinery (Safety) Regulations 2008.
- The Restriction of the Use of Certain Hazardous Substances in Electrical and Electronic Equipment Regulations 2012.

The following standards have been applied to the product(s):

- EN 55014-1:2017, EN 55014-2:2015, EN 61000-3-2:2014, EN 61000-3-11:2000, EN 62841-1:2015, EN 62841-3-9:2015+A11:2017.

The technical documentation required to demonstrate that the product(s) meet(s) the requirement(s) of the aforementioned legislation has been compiled and is available for inspection by the relevant enforcement authorities.

This product was placed onto the market: 2020

Product Description: 255mm Sliding Mitre Saw
Model number(s): CMS10S2B
Serial / batch Number: N/A
Date of issue: 04/03/2021

Signed:

J.A. Clarke
Director

A SELECTION FROM THE VAST RANGE OF

Clarke®

QUALITY PRODUCTS



AIR COMPRESSORS
From DIY to industrial, Plus air tools, spray guns and accessories.

GENERATORS
Prime duty or emergency standby for business, home and leisure.

POWER WASHERS
Hot and cold, electric and engine driven - we have what you need

WELDERS

Mig, Arc, Tig and Spot.
From DIY to auto/industrial.

METALWORKING
Drills, grinders and saws for DIY and professional use.

WOODWORKING
Saws, sanders, lathes, mortisers and dust extraction.

HYDRAULICS
Cranes, body repair kits, transmission jacks for all types of workshop use.

WATER PUMPS
Submersible, electric and engine driven for DIY, agriculture and industry.

POWERTOOLS
Angle grinders, cordless drill sets, saws and sanders.

STARTERS/CHARGERS
All sizes for car and commercial use.



PARTS & SERVICE: 0208 988 7400

Parts Enquiries
Parts@clarkeinternational.com

Servicing & Technical Enquiries
Service@clarkeinternational.com

SALES: UK 01992 565333 or Export 00 44 (0)1992 565335

Clarke INTERNATIONAL Hemnall Street, Epping, Essex CM16 4LG
www.clarkeinternational.com